

THANK YOU!

Thank you for purchasing the PAR Wave M715x/M716x. With technology specifically designed for your environment, your success is our passion.

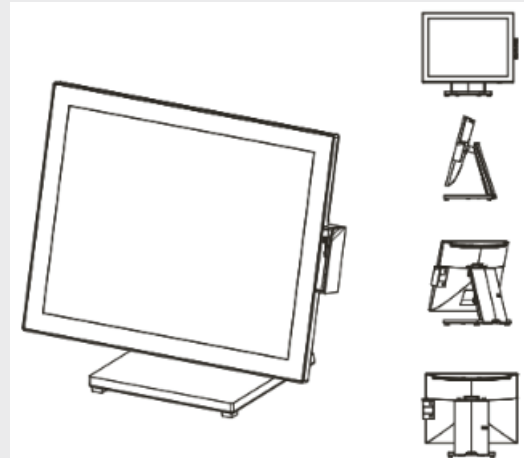

1 EXAMINE THE SHIPMENT



Please ensure all equipment is present.

Report any missing or damaged equipment to your PAR Salesperson or PAR Channel Partner.



2 INVENTORY COMPONENTS

Ensure you have the items listed below in your order.

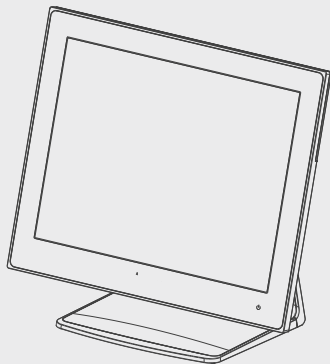

PAR Wave Terminal



Power Cord

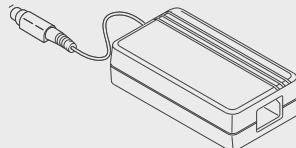

Adapter

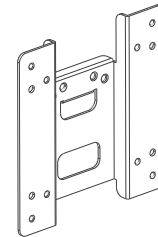

VESA Adapter Plate
(optional - may not be included with every order)

3 PRE-INSTALLATION OVERVIEW



1. Determine what type of installation you will need to complete for your store.
2. Gather information to complete the installation of your new system.
3. Inventory the equipment in your order.
4. Perform a backup of your current store information.
5. Understand pre-installation guidelines for your store.



Before installing your new PAR Wave system, ensure certain pre-installation guidelines are followed to protect the equipment, the store, and the employees. If you have any questions regarding the following guidelines, contact a PAR sales representative. If a store requires additional electrical wiring or network cabling, you may need to contact an electrical contractor to perform this work.



This material has been created in order to accommodate a wide range of restaurant operations and your specific business practices and system configuration may differ slightly from what is represented in this material. While ParTech, Inc. (“PAR”) takes great care to ensure the accuracy of these materials, all material is provided “as is” without warranty of any kind, either express or implied, including, but not limited to, warranties of merchantability or fitness for a particular purpose. PAR does not make any warranties or representations that the materials will meet your requirements or that the operations of the hardware will be uninterrupted or error free.

Trademark Notices: The PAR logo and PAR Wave™ are all trademarks of PAR Technology Corporation, the parent company of ParTech, Inc. or its affiliates. All other product names used throughout this material are trademarks of the respective companies. No such use of any trademark is intended to convey endorsement or other affiliation with these companies.

Reproduction: Copyright © 2024 ParTech, Inc. All rights reserved. This publication, or any part thereof, may not be reproduced or transmitted in any form or by any means, electronic or mechanical, including photocopying, recording, storage in an information retrieval system, or otherwise, without the prior written permission of ParTech, Inc., PAR Technology Park, 8383 Seneca Turnpike, New Hartford, NY 13413-4991; Phone: (315) 738-0600.

TABLE OF CONTENTS

Introduction & Connecting Power Page 4

Cable Well & Connecting Cables Page 5

Additional I/O, Safety..... Page 6

Optional Components Page 7

VESA Mounting Page 9

Maintenance & Support Page 10

REMOVING TERMINAL FROM BOX

Remove the terminal from the box by grasping the sides of the end caps and lifting up, then remove all packaging. Fold the bottom of the pedestal out and tighten the two Philips screws on stand bottom.

! **DO NOT** pull the terminal out of the box by lifting on the anti-static plastic bag. This may result in damage to the terminal.

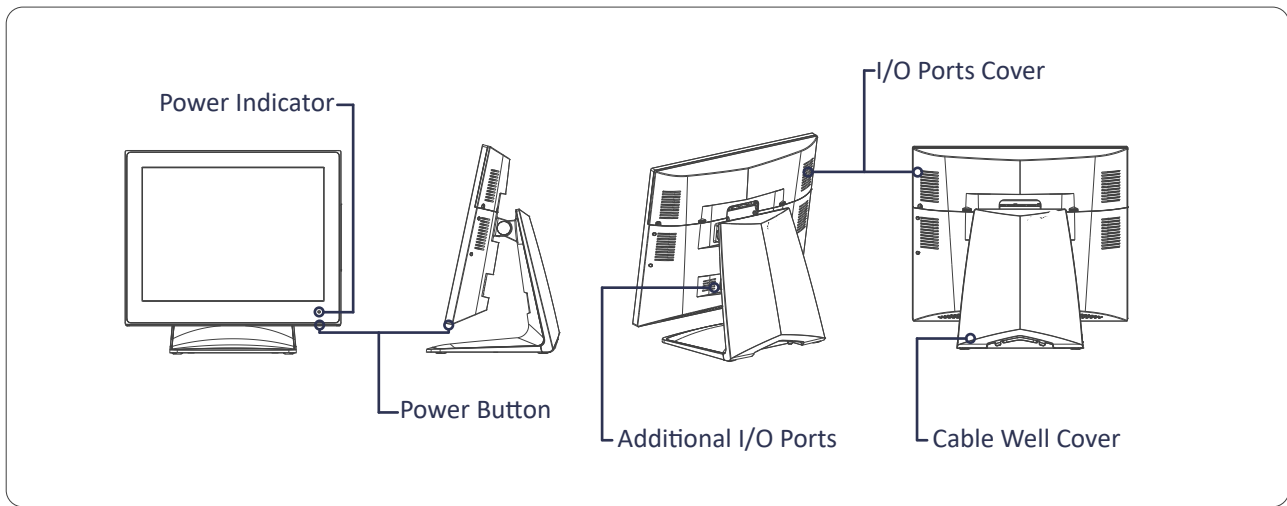

CONNECTING THE POWER CABLE

In order to power up the terminal you will be required to connect the power cable.

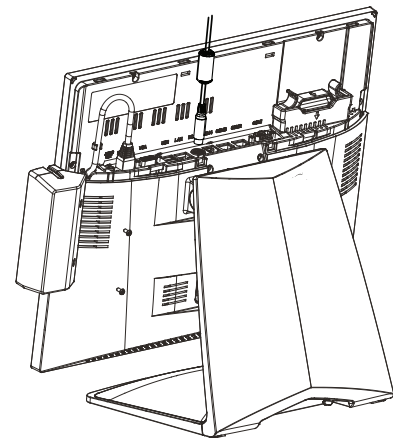

ACCESSING THE I/O WELL & CONNECTING CABLES

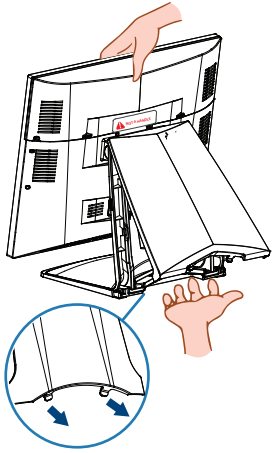

1 Remove the stand cover by holding the terminal with one hand and pulling the bottom of the stand cover by the cover hooks.

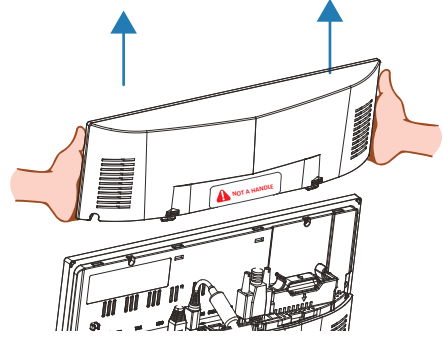
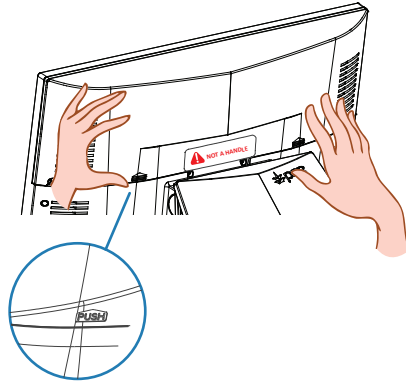

2 Remove the I/O cover by pressing the two tabs and pulling the cover straight up away from the terminal.

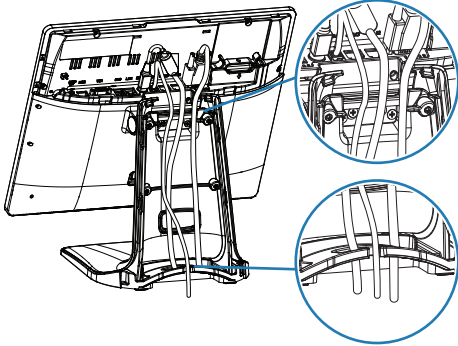

3 Connect your cables in the designated I/O ports and then route through the terminal stand.

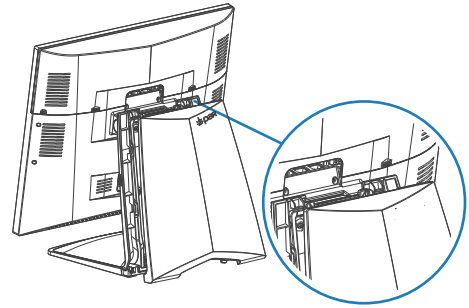
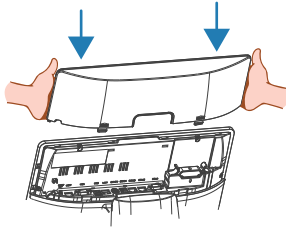

4 Replace the I/O cover onto the terminal and replace the stand cover by first connecting the top tabs then pressing on the bottom of the cover.

MAIN I/O BOARD

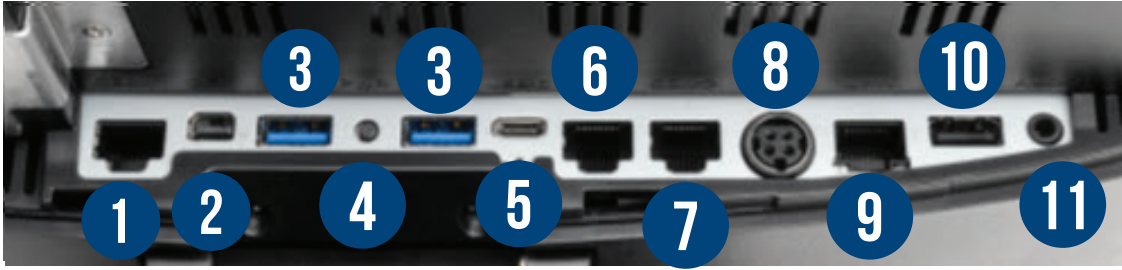

1	COM1
2	Mini DP
3	USB 3.0
4	Power Switch
5	USB-C
6	COM2
7	COM3
8	Power In
9	LAN
10	USB 2.0
11	Audio Out

ADDITIONAL I/O

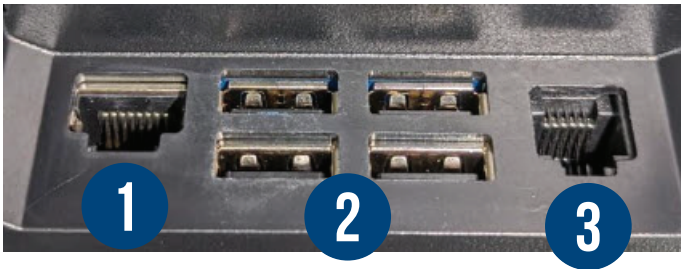

1	COM6
2	USB 2.0
3	Cash Drawer

PORT CAPACITY

USB-C: Input 12V / 5A, Output 5V / 1.5A

Cash Drawer: 24V / 0.2A

SERVICE & SUPPORT

For service and support after installation or to report any missing or damaged equipment, contact your PAR Sales Representative.



CAUTION BATTERY WARNING: A lithium coin-type battery is installed on the PAR Wave motherboard. If this battery is replaced, it must be replaced with an equivalent battery type. Dispose of the used battery according to the local disposal instructions.

SAFETY

- Before connecting cables or devices to connector wells, please turn off the power first thus preventing potential ESD damage.
- The service related to human safety is not allowed because this device may have the possibility of the radio interference.
- Risk of explosion if battery is replaced by an incorrect type. Dispose of used batteries according to the instructions.
- PAR Wave M715x/M716x terminals are EMC compliant for Class “A” digital device business purposes. The Buyer and/or Seller is advised that these limits are intended to provide reasonable protection against harmful interference in a commercial environment. Equipment is not intended for home use.

INVENTORY COMPONENTS

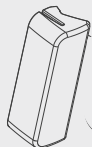

MSR Unit

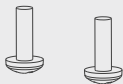

(2) M3x14
Phillips Screws

SOLD SEPARATELY

The installation requires the following tools:
Phillips head screwdriver

NOTE: There are several options for the MSR.
Your product may look different than the
image below.

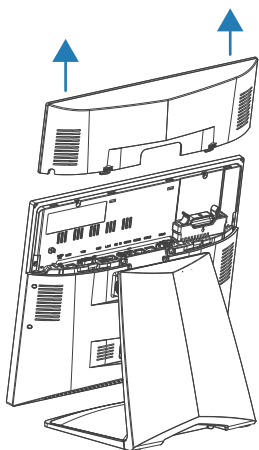

Power down the terminal.

1

Remove the I/O cover by pressing the two tabs and pulling the cover straight up away from the terminal.

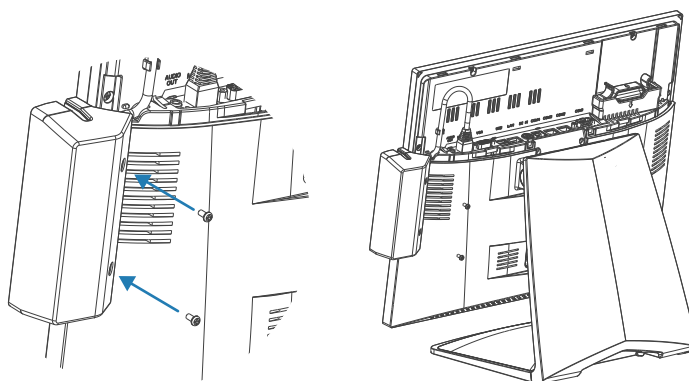

2

Plug the MSR/Biometric Unit into the side of the terminal and secure using the included screws.

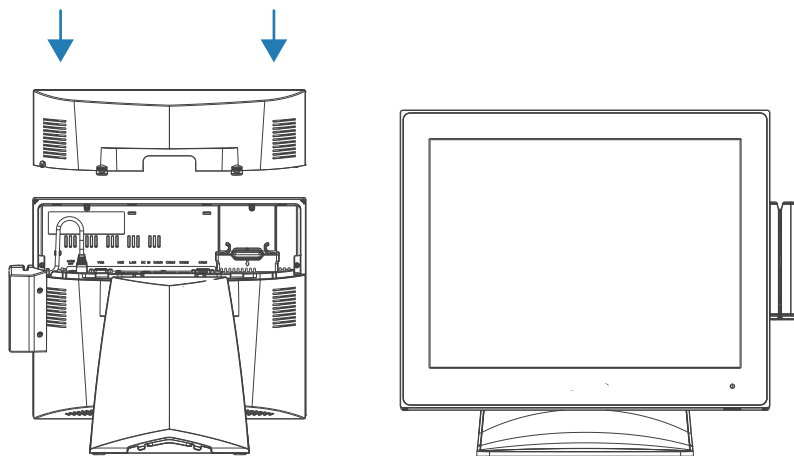

3

Replace the I/O cover.
Power up the terminal.

INVENTORY COMPONENTS

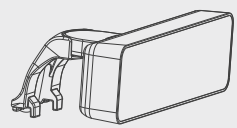

Customer Display

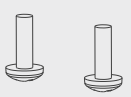

(2) M4x12
Philips Screws

SOLD SEPARATELY

The installation requires the following tools:
Phillips head screwdriver

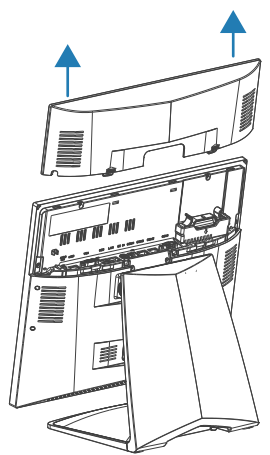

Power down the terminal.

1 Remove the I/O cover by pressing the two tabs and pulling the cover straight up away from the terminal.

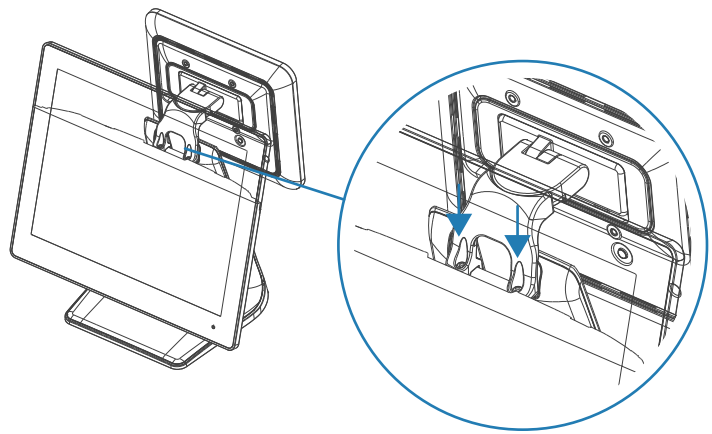

2 Attach the Customer Display to the terminal stand using the included screws.



3 Use the Mini DP port to connect display to terminal

4 Replace the I/O cover.
Peel film from display pulling left to right.
Power up the terminal.

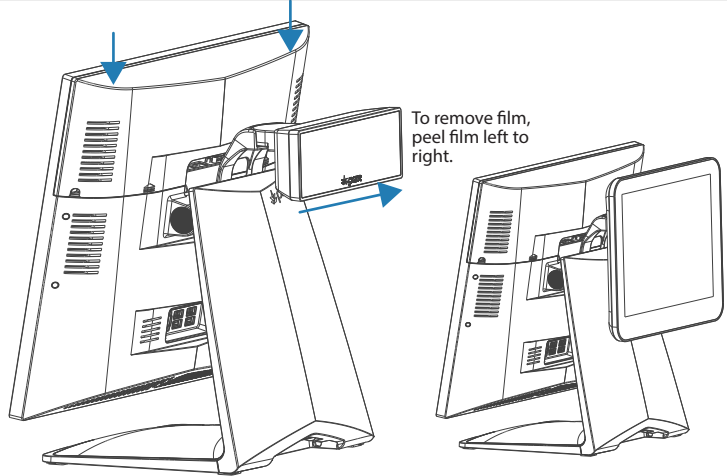

INVENTORY COMPONENTS

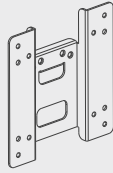

VESA Adapter Plate

The installation requires the following tools:
Phillips head screwdriver

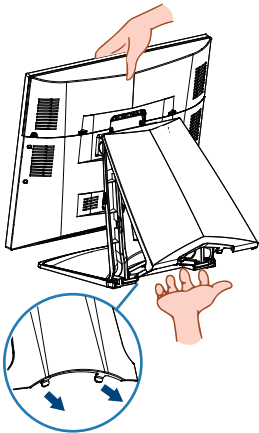

1

Remove the stand cover by holding the terminal with one hand and pulling the bottom of the stand cover by the cover hooks.

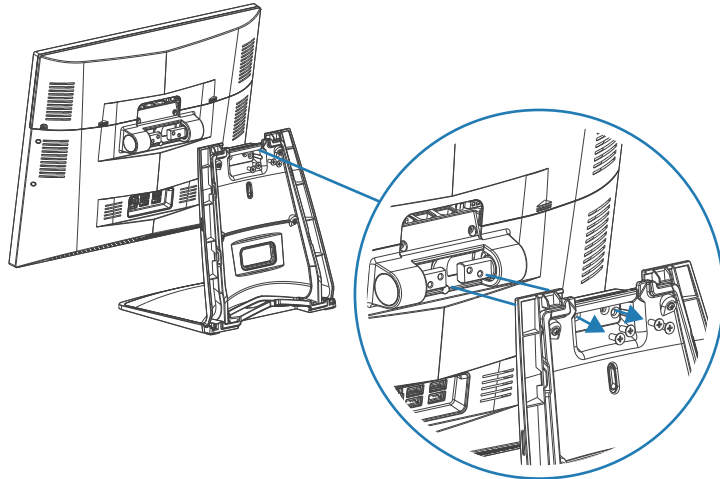

2

Remove the four screws connecting the stand to the touch screen.

KEEP THESE SCREWS FOR RE-USE.

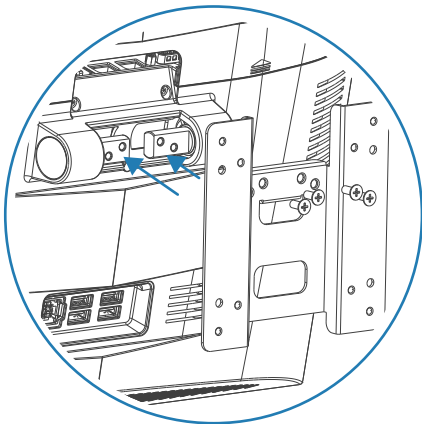

3

Using the four screws from the stand (Step 2), connect the VESA Adapter Plate to the touch screen.

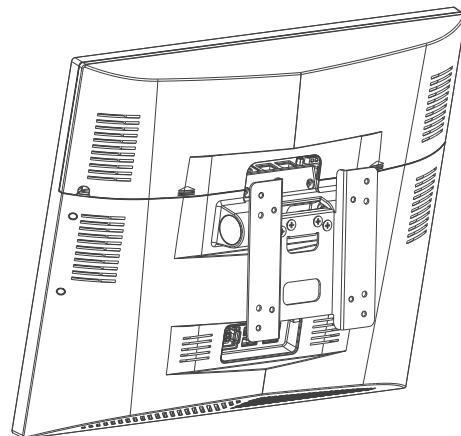

The terminal is now ready to be wall or pole mounted to customer-provided mount.

CARE OF EQUIPMENT

Prevent costly damage to your equipment:

- Do Not use equipment in direct sunlight or outdoors where exposed to weather and other natural elements.
- Never allow a unit to drop
- Never allow napkins, boxes, or other objects to block air vents on the printers, videos, PCs, or registers. These units have to "breathe" to operate efficiently.
- Make sure nylon or rubber grommet (washer) protects each hole punched through the counter top and other metal surfaces. Metal edges may cut through cables.
- Never break open a roll of coins by striking it against the cash drawer.
- Never switch a cash drawer with any other housing (case). The cash drawer and its housing are a matched set.
- Never drag a printer. Dragging weakens the cable. Lift a printer to move it.
- Always turn off or unplug units during power failures.
- Never unplug a unit when the power switch is on.

CLEANING EQUIPMENT

Clean the surfaces of the terminals often:

1. Turn off the unit.
2. Dampen a clean towel with carbonated water. Make sure the towel is damp, not saturated. Do not use ammonia based cleaning products.
3. Wipe off the unit with the damp towel. Never pour carbonated water directly on unit.
4. When done, turn the unit back on.



WARNING: Never use abrasive materials to clean the touch screen on a register. A scratch on the surface could disable the register, and result in costly repairs.

SUPPORT INFORMATION

Service:

USA: 800.382.6200

Canada: 800.387.4963

Parts:

USA: 800.PAR.PART

Canada: 800.387.4963

Drivers & Downloads:

support.partech.com